



**INSTRUCTIONS FOR THE USE,
MAINTENANCE AND SERVICING OF
WINDOWS**



MANUFACTURING PIKLAS WINDOWS	3
DELIVERY	5
REMOVING STICKERS.....	5
HUMIDITY DURING CONSTRUCTION	5
HEAT SHOCK.....	5
ANNUAL SERVICING OF WINDOWS	6
OPENING A WINDOW FOR CLEANING OR SERVICING.....	6
CLEANING THE GLASS.....	6
CLEANING AND SERVICING THE SASH	7
SEALING.....	8
SERVICING THE ROLLER LATCH OF A DETACHABLE GRILLE	9
CLEANING AND SERVICING VENETIAN BLINDS.....	9
CLEANING AND SERVICING PLEATED CURTAINS	10
SERVICING INSECT SCREENS, INSTALLATION OF INSECT SCREENS.....	10
SERVICING THE FITTINGS.....	10
FLIES AND OTHER INSECTS IN THE SPACE BETWEEN WINDOWS.....	11
TOP HUNG WINDOW WITH A WINDOW PUMP: RELEASING THE SASHES FOR SERVICING.....	12
OPENING AND MAINTENAC OF THE MORITE OPENING DEVICE.....	14
ADJUSTING THE SASH-TO-FRAME CLEARANCE.....	15
SAFETY STRINGS IN OPENING WINDOWS	16
WINDOW FROSTING AND PERCEIVED DRAFT	17
PRODUCT WARRANTY AND AGREEMENT TERMS	19
PROTECTIVE TREATMENT.....	19

MANUFACTURING PIKLAS WINDOWS

Windows are exposed to demanding climate conditions for decades. This is why Piklas windows are made of selected high-quality materials. During the manufacturing process, raw materials and components are meticulously selected, and raw materials undergo rigorous monitoring of homogeneity. The wooden parts of Piklas windows are made exclusively of special dried, sorted solid pine or glued pine blank. In paintable windows, all visible surfaces of the blanks are knotless. This eliminates any knot yellowing and twisting of the wooden parts. Our windows are always finished and fitted in accordance with the customer's wishes, within the framework of our product range.

FINISHES

Finishing options for the wooden parts of Piklas windows include overlay painting (special RAL colours available on demand), varnishing, or colourless protective treatment. There are five standard colours available for painting exterior aluminium parts.

OVERLAY COLOURS FOR WOODEN PARTS



White

Light grey

Deadwood grey

Dark grey

Carbon black



Latte

Yellow soil

Warm red

Turquoise

RAL specialcolours

VARNISH COLOURS FOR WOODEN PARTS



You can find bigger pictures of varnish colours from our webshop
<https://piklas.ikkunaverkkokauppa.fi/>

ALUMINIUM COLOURS FOR EXTERIOR SURFACES



FITTINGS

The windows are delivered from the factory with fittings. Standard colours for fittings include white for standard white windows, chromium for other colours. Matte chromium and black available on demand.





DELIVERY

The window package is protected with plastic film for short-term (approx. 2 to 3 weeks) site storage. Upon receipt of the goods, the recipient becomes the holder of the goods instead of the manufacturer. It is the purchaser's duty to immediately inspect the product upon receipt. The recipient must inspect the physical condition of the package as soon as it arrives. Any tears or holes in the package must be patched with plastic or sticky tape. Visible transport damage must be recorded in the electronic consignment note, pictures of the damage must be taken while still on the transport platform, and the manufacturer must be notified immediately to expedite the compensation process. Do not install a defective product without permission from the manufacturer. For storage, the windows must be placed on a dry surface, ensuring sufficient ventilation and protecting the products with tarpaulins.

REMOVING STICKERS

Any stickers present on the glass surfaces must be removed as soon as possible (this does not, however, include any labels related to the use of the window such as safety glass labels) to prevent sun-induced staining of the glass. Solvents such as cooking oil, white spirit, isopropanol or acetone can be used for removing stickers. Care must be taken when using solvents to avoid their contact with any other surfaces than glass and to ensure good ventilation of the area. When using tools such as window scrapers, care must be taken not to scratch the glass. Any stickers denoting thickness of the glass must not be removed.

HUMIDITY DURING CONSTRUCTION

Humidity of installed windows during construction, and disadvantages thereof, must be considered and eliminated because they constitute a significant load factor on the windows. Humidity in windows may cause flaws such as opening or staggering of the joints and peeling of the paint. The inner sash and inner parts of the frame are intended for dry interiors, similar to home fixtures. For additional information on humidity during construction and for those who build during winter in the Instructions section → <https://www.piklas.fi/ohjeet-takuutiedot>

Ready, finished wooden surfaces undergo appearance inspection two years after the completion of the property to allow the offset of construction humidity. (RT- 103241). Any deviations in the surface quality detected upon receipt of product or during construction must be notified to the factory.

HEAT SHOCK

Black/dark curtains/blinds or shades as well as other dark objects (sofas, for example) near the window, together with sunshine, may cause heat shock that can break the glass. The manufacturer's warranty does not cover such damages due to external factors.



ANNUAL SERVICING OF WINDOWS

Remember to inspect the general condition of the windows every year. For example, remove any trash that may block air inlets. In winter, snow on the exterior windowsill may block the circulation of air, causing the window to frost. Also inspect the leakproofness and adjust the sash-to-frame clearances, if needed.

OPENING A WINDOW FOR CLEANING OR SERVICING

Window sash locks are opened with a separate handle. The sash is opened steadily from both the upper and lower part to avoid twisting the sash and breaking the glass. For large windows, sash opening can be facilitated by lifting the outer stile of the sash with the handle placed in the lock. When opening casement windows over 150 cm wide, the window must be supported from below.

Hold-open restrictors are usually used for ventilation windows. When the window is opened as usual by the handle, a restrictor can be seen at the lower part of the inner and outer sash that restricts the opening of the sash. The restrictor can be released for servicing and cleaning by opening the restrictor lock on the lower rail of the inner sash, for example by pressing the window release button.

If needed, the restrictor can be serviced when opened by using a damp cloth and detergent to wipe off any dirt. After servicing and cleaning, the restrictor must be locked again.

CLEANING THE GLASS

It is recommended to regularly clean the glass surfaces. Sufficient cleaning frequency depends on the quantity of dirt in the environment. To achieve glass surfaces that are clear and let light in, it is worthwhile to clean the surfaces when the dirt is still easily detachable: better to do it frequently with light washings than rarely, requiring heavy scrubbing. Stains or debris beyond normal dirt must be removed immediately; a typical first time is right after completing the construction.

In some cases, stains such as suction cup marks may remain on the glass surface and become visible upon cleaning or frosting. This is due to a fat residue buildup on the glass surface, which is hard to remove in one washing. However, it will fade off in time after several washings and normal evaporation.

For cleaning the glass, use lukewarm water with mild detergents such as liquid soap to reduce the surface tension of water. Avoid using strong alkaline detergents. In the cold season, even diluted windscreen washer fluid can be used for cleaning windows.



Recommended cleaning routine

- Rinse away any loose dirt with abundant water.
- Prepare a mild solution of surface tension-reducing detergent in clean water.
- Spread the solution to a suitable area and wipe with a soft, lint-free cloth or sponge as needed
- Rinse and dry

Special stains

If a stain is not removed by the normal washing routine, try to clarify the origin of the stain and the solvent needed.

Glass can withstand commonly used solvents; however, this is not the case for glazing materials, sealants, etc!

At the end, carefully rinse off any remaining solvent. A mixture of citric acid and water has also shown to be an efficient combination to remove, for example, the aforementioned suction cup marks.

During installation or painting the walls, the glass surface may be stained with paint, glue, varnish, silicone, etc. These can be removed using a razor blade or other similar blade with a handle. These must be used with care to avoid scratching the glass surface. The blade must be sharp enough to cut off the impurity at the boundary between glass and stain.

Tempered safety glass and glasses of EkoEnergy-windows– *important note*

The exterior sash of EkoEnergia windows is made of coated glass. It must not be cleaned using metal objects. Additional information in the separate cleaning instructions for Piklas windows.

You can find the instructions at <https://www.piklas.fi/ohjeet-takuutiedot>

Due to the surface tension of tempered glass, it is more easily scratched than normal glass. This is why tempered glass must be handled and cleaned with extra care.

CLEANING AND SERVICING THE SASH

The sash surfaces should be cleaned about once every six months. General grocery store detergents can be used for cleaning; however, do not use products that contain abrasives. Stubborn dirt can be cleaned using a soft cloth with white spirit, for example, immediately followed by normal washing.

Refinishing wooden parts with paint or varnish

Window finishes, especially on the exterior surfaces, should be inspected annually (MSES and MS type wooden windows, in particular). If the surface has suffered any dents or chips, these should be repaired immediately. Windows on the south and west side of the house often require more servicing than those on the north and east side. The humidity content of a wooden window should not exceed 15% prior to refinishing. This is why it is good to do the



refinishing (especially on exterior surfaces) in spring or early summer. Relative humidity in the air is at its highest in late summer and autumn, hampering the drying process of refinishing materials. Painting should never be carried out in the heat of the sun because this will cause the materials to dry too quickly, leading to defective adhesion and film formation.

1. Scrape off any paint that has cracked or peeled off.
2. Sand down glossy paint surfaces and round any sharp corners.
3. Wipe the sanding dust off of the paint surfaces.
4. Treat exterior painting surfaces with a mould washing solution / neutral detergent.
5. Prime exposed wooden surfaces with a colourless wood preservative, for example.
6. Patch any cracks or holes with putty (1- or 2-component putty).
7. For exterior surfaces, apply 2 to 3 layers of water-soluble paint or varnish for outdoor use.
8. Interior surfaces can be refinished using paint for indoor use.

The white colour is called joinery white, code NCS-S-0502-Y semigloss.

Refinishing aluminium parts using a brush or spray

Relative humidity must be less than 80% when the painting is carried out.
The temperature should be +10°C at the minimum.

A. Minor repairs where the paint film damage does not reach the underlay

1. Sand down lightly.
2. Remove any loose sanding dust.
3. Apply refinishing paint.

B. Abraded paint where the underlay can be seen

1. Sand down well.
2. Remove any loose sanding dust.
3. Apply primer.
4. If needed, sand down again.
5. Apply finishing paint.

The white colour for aluminium parts has the code RAL 9010

SEALING

Painted and varnished Piklas windows are delivered sealed with high-quality TPE seals with a lifespan of over 5 years in normal use. The seals must be inspected annually and, when their renewal is needed, it is recommended to use tube profile seals made of EPDM, TPE, or silicone rubber with similar form. You can buy the seals at Piklas: ask for a quote at our webstore using the Contact form <https://piklas.ikkunaverkkokauppa.fi/ota-yhteytta>

SERVICING THE ROLLER LATCH OF A DETACHABLE GRILLE

Fasteners of window grilles installed on the exterior can accumulate impurities from rainwater, and the inner surface of aluminium profiles can also become covered in soot over time. This can cause the roller latch to work less smoothly, and servicing is needed.

First apply a sharp tap on the grille to ease the static friction between the mounting holes and mounting pins. You can use the shaft of a hammer or a screwdriver, for example.

Pull the roller latch fastener completely out of the aluminium profile.

Brush some oil on both sides of the roller latch.

Push the roller latch back to its place and roll it a few times to spread the lubricant.

Install the grille back on its place.

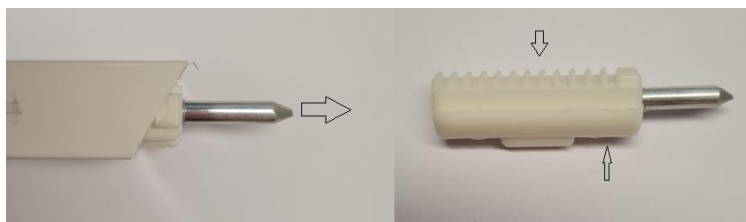

Nowadays, grilles are fastened with a **sliding latch**. They are adjusted by tightening or loosening a screw on the grille



CLEANING AND SERVICING VENETIAN BLINDS

Venetian blinds placed in the space between double-glazed windows do not usually accumulate dust. If there is dust (especially for non-integral blinds on the interior surface of the window), it can be gently wiped off with a feather duster or a blind cleaner.

The blinds and their strings can be cleaned using general grocery store detergents. Do not use abrasive or acidic detergents; slightly alkaline (pH 8 to 10) detergents are recommended.

CLEANING AND SERVICING PLEATED CURTAINS

Pleated curtains do not require any special servicing. If needed, they can be cleaned by wiping with a damp cloth.

SERVICING INSECT SCREENS

Insect screens should be removed in the autumn and cleaned of any insects. If needed, the screen can also be washed with lukewarm water. In winter, insect screens should be stored to prevent birds from pecking any remaining insects, which may cause breakage of the mesh. At the same time, it is good to reduce the exterior sash-to-frame clearance by adjusting the hinges and the restrictor arm.

Installation guide:

Open the window and install the insect screen in the window. Push the silicone fastener down into the window frame trim in such a way that its upper flap presses the insect screen into place. Install the second fastener into the top window frame trim of the insect screen.

The second flap of the silicone fastener bends upwards and presses the insect screen against the window frame trims. The lower flap of the fastener stays under the edge of the insect screen.

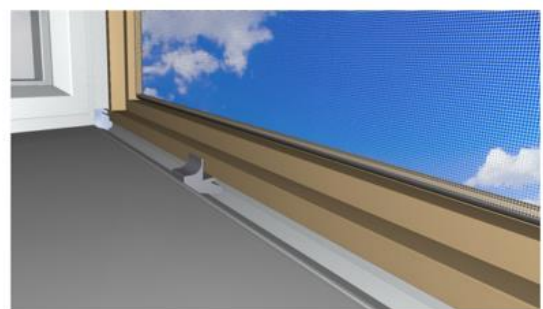

SERVICING THE FITTINGS

Hinges should be oiled lightly once every two years (about 1 drop per hinge). Locks should be oiled lightly at least once per year (2 drops per lock). Lever bolts and restrictors in ventilation windows and panels should be oiled lightly once per year. Use a light general or teflon oil, for example: sewing machine oil, gun oil, lubricating oil (WD-40 or CRC).

After oiling, remember to clean any remaining oil off of the sash and the glass. Inspect the fastening of fittings on the surface and, if needed, tighten the screws.

FLIES AND OTHER INSECTS IN THE SPACE BETWEEN WINDOWS

Especially during autumn, flies and other insects may wander into the space between double-glazed windows when seeking warmth. Accessing the in-between space is not due to a product defect. Access of flies and other insects into the in-between space can be reduced by covering the weep holes with water permeable mesh. If this is done, care must be taken to ensure that the mesh still allows the circulation of air and drainage of water. The mesh must be kept clean at all times so that it will work as intended and not break or develop mould. Care must also be taken to ensure that covering the holes does not prevent the removal of moisture and sufficient ventilation, which can void the warranty of the window structures.

Installing the fly seal: the purpose of the seal is to protect the weep hole (indicated by an arrow) without preventing drainage of water from between the window. The seal is installed on the lower exterior windowsill, all the way to the bottom, as shown in the figure.

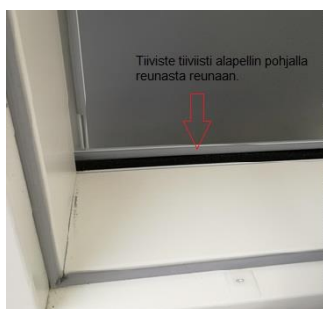

TOP HUNG WINDOW WITH A WINDOW PUMP: RELEASING THE SASHES FOR SERVICING

Open the window to ventilating position (choose correct instruction - see model figures below).

Hold-open model before March 2024: release the hold-open restrictor that connects the interior and exterior sashes (see figures below).



Hold-open model from March 2024: release the the interior and exterior sashes from each other by pressing the opening button of the holding device



Before releasing the window pump, support the sash with the help of aid or another person.



Release the locking pin of the window pump by slightly cranking it up and removing it downwards (figure below).

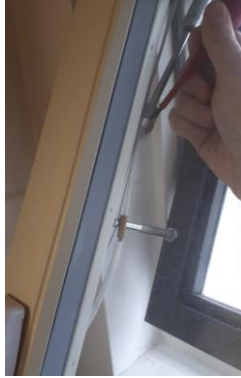

After removing the pin, the pump is released by lifting the pump (the locking buckle may differ slightly depending on window manufacturing date).

If the window has pumps on both sides (wide windows), repeat this for the other pump as well. Now the sashes are hanging freely on their hinges for servicing.

After servicing, repeat all stages in reverse order.

OPENING AND MAINTENANCE OF THE MORITE OPENING DEVICE

The Morite hold-open device is in Piklas' openable windows with a frame depth of 96mm or 115mm.

1. The hold-open device is opened for maintenance and washing by opening the lock of the intermediate shutter at the bottom of the inner frame. Pull the lock towards you, this way the outer frame is released from the inner frame. If the lock does not open by pulling, then use a side cutter, chisel, etc., with which you can pull the lock open.
2. The holding device should be serviced upon opening by wiping the dirt with a damp towel and detergent. The locking mechanism should be lightly oiled when cleaning.
3. The holding device must be locked back after maintenance and washing. If the locking is still tight, you can add a little oil. If necessary, you can press the locking tab with a chisel.



1.



2.



3.

ADJUSTING THE SASH-TO-FRAME CLEARANCE

The sash clearance has been adjusted at the factory prior to delivery. The adjusted clearances can change upon installing the window, which is why further adjustment is recommended after installation to ensure flawless operation.

Window sashes can also change positions over time due to, for example, aging of the building. This is why it is good to inspect the sash-to-frame clearances annually. If needed, the clearance can be adjusted by removing the sash and rotating the hinge (from either the sash or the frame side) no more than two rounds.

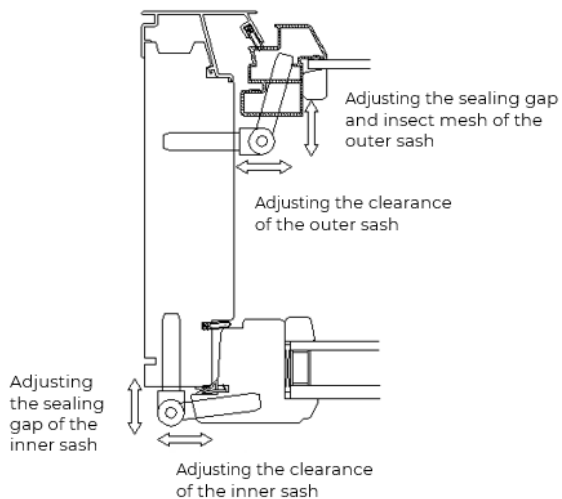

Detach the hinge pins and the sash from the frame, and rotate the hinges on the frame or on the sash:



If the upper rail of the inner sash is touching the frame: rotate the lowest hinge of the inner sash inwards two rounds. The adjustment can be enhanced by rotating the top hinge outwards.

If the stile of the inner sash is touching the frame or the lock cannot reach the striking plate: rotate the inner sash hinges 1 to 2 rounds inwards or outwards. Try out and, if needed, adjust again.



SAFETY STRINGS IN OPENING WINDOWS

Piklas bottom hung and emergency exit window packages are delivered with a safety string and instructions for its installation. Delivered in a pouch between the sashes. The safety string must be installed in place to ensure safe usage.

In March 2024, the device to hold the windows open changed in openable windows frame depth 130 – 200 mm , which changed the need for a safety cord.

The new safety cord rule is as follows: bottom-hung ventilation windows 1190 and wider or if the bottom-hung window is higher than 600, the windows come with a safety string(s) with installation instructions in the Piklas window package.

NOTE! If the window frame depth is 96 mm or 115 mm, the safety cord must still be installed in place in all emergency exit windows and ventilation windows that are hinged down. They have the MORITE mechanism as the holding mechanism (the picture can be seen on page 13 of this manual). This mechanism requires a safety cord to ensure operational safety.

The safety devices of the bottom hung window must always be locked. However, when performing maintenance procedures, the frames are opened, in which case the uncontrolled opening of the frames must be taken into account.



WINDOW FROSTING AND PERCEIVED DRAFT

Frosting of the inner surface of the outermost glass (in Figure A.)

Frosting of the inner surface of the outermost glass (A.) is caused by warm and humid indoor air in the space between the double-glazed windows. Humidity is condensed on the coldest surface of the in-between space: the inner surface of the outermost glass. This problem occurs in buildings where ventilation has been adjusted to positive pressure, or where the air extraction fan or extraction flues are inadequate.

Frosting may also be due to freezing of the VU heat recovery cell (freezing protection has been adjusted incorrectly), causing positive pressure in the building. This problem occurs most commonly upstairs because heat and humidity rise up, causing a higher pressure upstairs.

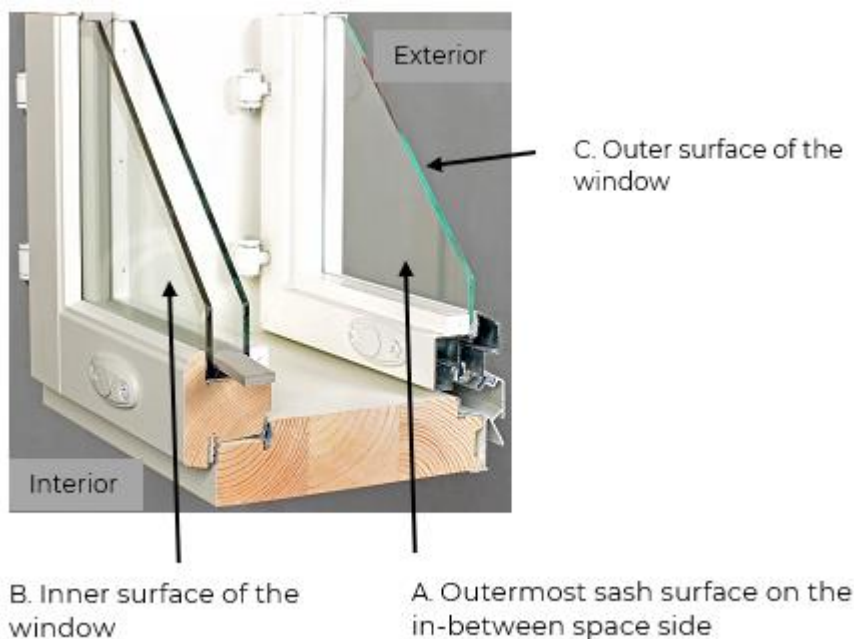

If there is still frosting after inspecting the abovementioned factors related to ventilation, the next thing to check is leakproofness of the interior sash. Check that the interior sash locks are properly closed, the sealings are intact and undergo uniform and sufficient compression on all sides of the sash upon closing. The sealing gaps and sash-to-frame clearances can be adjusted by rotating the frame and sash hinges. Sealing gap between the interior sash and the frame should be approx. 3 to 4 mm.

The problem may also be due to an error during the construction phase. The window frame screws have been closed too tightly, causing the frame to spread out, which can cause the sealing gaps to leak or the frame to deviate from the crosswise measurements. This problem can be fixed by straightening the frame with a wedge.



Frosting of the inner surface of the outermost glass may also be due to oversealing of the exterior sash (which is rare), leading to insufficient ventilation of the in-between space. (For example, snow on the exterior windowsill has blocked the air vents under the window.) This frosting problem can be fixed by increasing ventilation. Remove a suitable quantity (by experimenting in small increments) of the upper and lower sealing on both sides of the exterior sash to improve the circulation of outdoor air. Condensation to the in-between space can be avoided by keeping the room at a slight negative pressure, as recommended.

Frosting of the outer surface of the outermost glass (in Figure C.)

This phenomenon is becoming more common due to the use of modern energy-efficient windows (U-factor below 1.0). The phenomenon is caused by the low level of "waste heat" from the interior, insufficient to keep the exterior glass temperature higher than its surroundings and allowing it to reach dew point. This is not a defect but a property of the window. Exterior humidity does not cause harm to the structures of the window. Our range of low energy windows includes a non-frosting option, FrostFree, that features very low frosting of the exterior surface.

Frosting of the interior glass (in Figure B.)

This phenomenon is rare in modern windows. Temperatures of structural surfaces and humidity in indoor air may cause interior condensation. Factors affecting humidity include plants, cooking, sauna, air humidifiers and defective ventilation, for example. *Well-functioning ventilation* minimizes conditions that increase condensation. Curtains, for example, can block the circulation of warm air to the interior glass surface, giving rise to condensation of indoor air humidity on the cold surface. After a window renovation, for example, it is worthwhile to check that heating and ventilation match up to the new conditions.

Perceived draft in the room

The feeling of draftiness is always linked to ventilation. The first thing to check is to ensure that ventilation is working as planned. A drafty sensation is usually due to one of two reasons: either the window locks are not closed, or the valve in the upper part of the sash is bringing in make up air (if the windows are equipped with make up air valves). Check that the window locks are closed and check how to use the valves properly.



PRODUCT WARRANTY AND AGREEMENT TERMS

Piklas Oy grants a product warranty of three (3) years to windows of their manufacturing. The warranty covers the technical structure and materials of the windows as well as technical properties thereof, as defined in the order and trade documents. In addition, the warranty covers window equipment such as fittings, blinds, and other corresponding accessories. The seller is not liable for defects caused by normal wear and tear or the buyer's negligence.

The glass manufacturer grants a 5-year warranty for the leakproofness of the glass unit.

Piklas operates in accordance to the general procurement and delivery terms for construction products (RYHT2000).

More detailed product warranty and agreement terms can be found at:

<https://www.piklas.fi/ohjeet-takuutiedot>

PROTECTIVE TREATMENT

Wood-finished, protective-treated windows and doors have been proofed against wood-rotting and blue stain fungi at the factory. The protective treatment also provides a good underlay for further treatments.

FACT SHEET: Objects treated with TEKNOL AQUA 1410-01

This object has been treated with wood preservative: (Biocidal Products Regulation 528/2012, PT8)	TEKNOL AQUA 1410-01
a) Objects treated with TEKNOL AQUA 1410-01 contain:	Biocidal substances approved for product type 8
b) Objects treated with TEKNOL AQUA 1410-01 are protected against:	Wood-rotting fungi or blue stain fungi
c) Objects treated with TEKNOL AQUA 1410-01 contain the following biocidal products:	Propiconazole, IPBC
d) Objects treated with TEKNOL AQUA 1410-01 contain the following nanomaterials:	-
e) Special precautions for objects treated with TEKNOL AQUA 1410-01:	To protect aquatic organisms, treated wood must not be used in aquatic environments or immediate surroundings thereof (for example, rivers, creeks and lakes)
TEKNOL AQUA 1410-01 wood preservative is manufactured by:	Teknos A/S Industrivej 19 DK-6580 Vamdrup Tel. +45 76 93 94 00

30.10.2024